

**End of Course Assessment (EOC): Final Study Guide**  
*Digital Electronics*

**Directions:** Complete all of the work in your engineering notebook. Completion of this review study guide will count like an engineering notebook check worth 30 points.

- A. Scientific Notation vs. Engineering Notation
- Explain how to write numbers in scientific notation.
  - Explain how to write numbers in engineering notation.
  - What are the SI prefixes that you will need to memorize in order to write numbers in Scientific notation or engineering notation?
- B. Component Identification: Resistors and Capacitors
- What is a resistor?
  - How do you determine the nominal value for a resistor?
  - What is a capacitor?
  - How do you determine the nominal value for a capacitor?
- C. Circuit Theory Laws:
- What is current, voltage, and resistance?
  - What is Ohm's Law?
  - What is the difference between Parallel Circuits and Series Circuits?
- D. Analog vs. Digital Signals
- What is a logic level?
  - What is an analog Signal?
  - What is a digital Signal?
- E. Number Systems
- Binary
    - i. Why do engineers use the binary system to express numbers?
    - ii. How do you convert from decimal → binary and from binary → decimal?
  - Octal
    - i. How do you convert from octal → Decimal and from decimal → octal?
  - Hexadecimal
    - i. How do you convert from hexadecimal → decimal and from decimal → hexadecimal?
- F. Combinational Design Logic: AOI
- What is AOI Logic? What do each of the gates represent in AOI logic?
  - How do you write a truth table if given 2 inputs, 3 inputs, etc.?
  - How do you find minterms from a truth table?
  - How do you write a logic expression from minterms or from a truth table?
  - How do you draw circuits from logic expressions?
  - How do you derive a truth table from an existing circuit using "method 1"?
  - How do you derive a truth table from an existing circuit using "method 2"?
- G. Alternative Combinational Design Logic:
- NAND Logic
    - i. What is NAND logic? What do each of the gates represent in NAND logic?
  - NOR Logic
    - i. What is NOR logic? What do each of the gates represent in NOR logic?
  - What are the pros/cons of using NAND/NOR logic over AOI logic?
- H. Circuit Simplification Techniques
- i. Boolean Algebra
    - Explain how to simplify logic expressions using Boolean Algebra.
  - ii. DeMorgan's Theorems
    - Explain how to simplify logic expressions using DeMorgan's Theorems.

### iii. K-Mapping

- Explain how to simplify logic expressions using the K-mapping technique.

### I. Seven Segment Displays

- What does each “segment” represent?
- What is the different between a Common Anode and a common cathode?
- Explain how you could display any number using a seven segment display.

### J. Multiplexers and DeMultiplexers

- What are they?
- Provide examples of each

### K. Binary Addition

- Explain how you perform binary addition/subtraction.

### L. XOR/XNOR

- What is XOR/XNOR Logic? What do each of the gates represent in AOI logic?
- Be sure to know the truth table and the logic expressions for both XOR and XNOR gates.
- What is the difference between a half-adder and a full adder?
- How do you determine the ‘Sum’ and the ‘Cout’?

### M. Flip-Flops

- What is a Flip Flop?
  - i. D Flip Flops vs. J/K Flip Flops
  - ii. Positive Edge Trigger vs. Negative Edge Trigger
- How to you determine the signal of “Q” for a D flip flop and a J/K flip flop? Hint: Memorize the table
- What are asynchronous inputs?
- What are the functions of the present and the clear?
  - i. Make sure that you can draw the signal of “Q” for a D flip flop that has a preset and clear!
- What is an asynchronous counter?
  - i. What determines the count limit?
  - ii. What is the ripple effect?
  - iii. What is the different between an up-counter and a down-counter?
  - iv. What are 2 limitations of asynchronous counters?
  - v. How do you modify a flip flop to count from 0→5 ?
- What is a synchronous counter?
  - i. How to you create a synchronous counter?
  - ii. **MEMORIZE THE TRANSITION TABLE FOR J/K FLIP FLOPS!**
  - iii. How do you determine the logic for a synchronous counter using the transition table?
- What is MSI?
  - i. What is the difference between the 74LS163 and the 74LS193 MSI logic chips?

### N. State Machines

- What is a state machine?
- What are some examples are of state Machines?
- How do you draw a state graph?
- What are state variables?
- How do you draw the transition table from the state graph?

## EXAMPLE PROBLEMS

### Scientific Notation vs. Engineering Notation

1. Express the following quantities in Scientific Notation and Engineering Notation

	Scientific	Engineering
a. 9437502876	_____	_____
b. .000031645	_____	_____
c. .00000006185	_____	_____
d. 431 T $\Omega$	_____	_____
e. 0.00000000356	_____	_____
f. 934,000,000	_____	_____
g. 3,510,000	_____	_____
h. 0.00092	_____	_____

### Component Identification: Resistors and Capacitors

2. If the given the color bands, find the value of each resistor and the calculated tolerance. If given the value of a resistor, find the color bands and calculate the tolerance.

Color Bands	Value	Tolerance
Red, blue, green, silver	_____	_____
Red, red, black, gold	_____	_____
Green, red, brown, silver	_____	_____
Violet, orange, orange, silver	_____	_____
_____	470K $\Omega$ $\pm$ 5%	_____
_____	2.2M $\Omega$ $\pm$ 5%	_____
_____	4.7K $\Omega$ $\pm$ 10%	_____
_____	3.3K $\Omega$ $\pm$ 5%	_____

## Circuit Theory Laws:

### Ohm's Law

Equation	Variables	Units	Unit Symbols
Current = $\frac{\text{Voltage}}{\text{Resistance}}$	$I = \frac{V}{R}$	Ampere = $\frac{\text{Volts}}{\text{Ohms}}$	$A = \frac{V}{\Omega}$

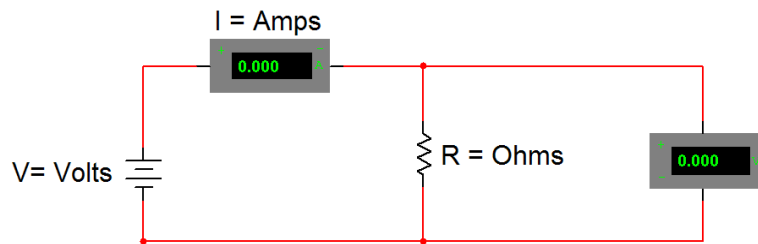

- On a camping trip, you decide to use a cordless air pump to inflate an inflatable mattress. If the air pump is powered by a 9 volt battery with a resistance of 18 ohms, what is the amount of current flowing through the circuit?
- A DJ uses a 110 volt outlet to plug in a strobe light. If the current flowing through the light is 0.050 amps, how much resistance is within the circuit?
- You finally found the MP3 player that you have wanted for months. While you are waiting in the check-out line, you read the back of the packaging. The manufacturer has guaranteed that the player will perform consistently with a resistance of 40 ohms and a current of 0.1 amps. What is the voltage for the MP3 player?

6. Use the image below to answer the questions

(Voltage across the battery is 9 v).

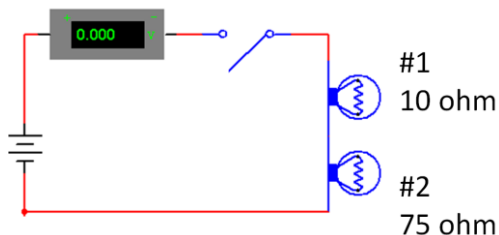

Current \_\_\_\_\_ A

Voltage across battery \_\_\_9\_\_\_ V

Voltage across bulb #1 \_\_\_\_\_ V

Voltage across bulb #2 \_\_\_\_\_ V

**Creating a Parallel Circuit**

7. Solve the circuit shown below (Voltage = 9v). Once the switch is closed find the values below:

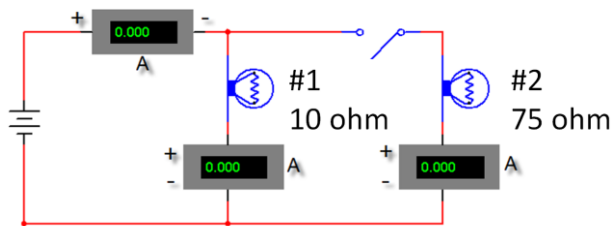

Current at bulb #1 \_\_\_\_\_ A

Current at bulb #2 \_\_\_\_\_ A

Current total \_\_\_\_\_ A

Bulb #1 \_\_\_\_\_ V

Bulb #2 \_\_\_\_\_ V

**Creating a Combination Circuit**

8. Solve the circuit shown below.

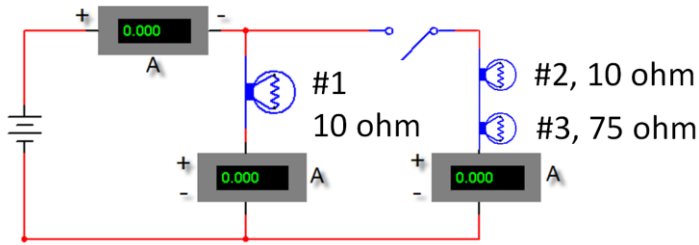

Voltage across battery 9V

Voltage across bulb #1 \_\_\_\_\_ V    Voltage across bulb #2 \_\_\_\_\_ V

Voltage across bulb #3 \_\_\_\_\_ V

Current at bulb #1 \_\_\_\_\_ A

Current at bulb #2 and #3 \_\_\_\_\_ A

Total current \_\_\_\_\_ A

Total Resistance \_\_\_\_\_ ohm

9. Explain the difference between a series and a parallel circuit.

10. Explain the difference between the *voltage* output at the battery and the voltage across each bulb in the series circuit.

11. Explain the relationship between the *voltage* output at the battery and the voltage across each bulb in the parallel circuit?

## Analog vs. Digital Signals

12. For each of the two analog signals shown below, determine the amplitude (peak), amplitude (peak-peak), period (T), and frequency (F). Be sure to put your answer in proper engineering notation and use the correct units.

Amp (peak):

Amp (peak-peak):

Period:

Frequency:

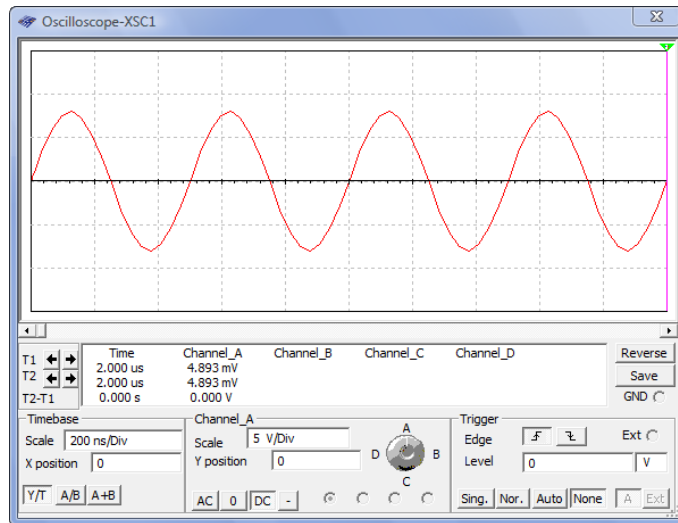

Amp (peak):

Amp (peak-peak):

Period:

Frequency:

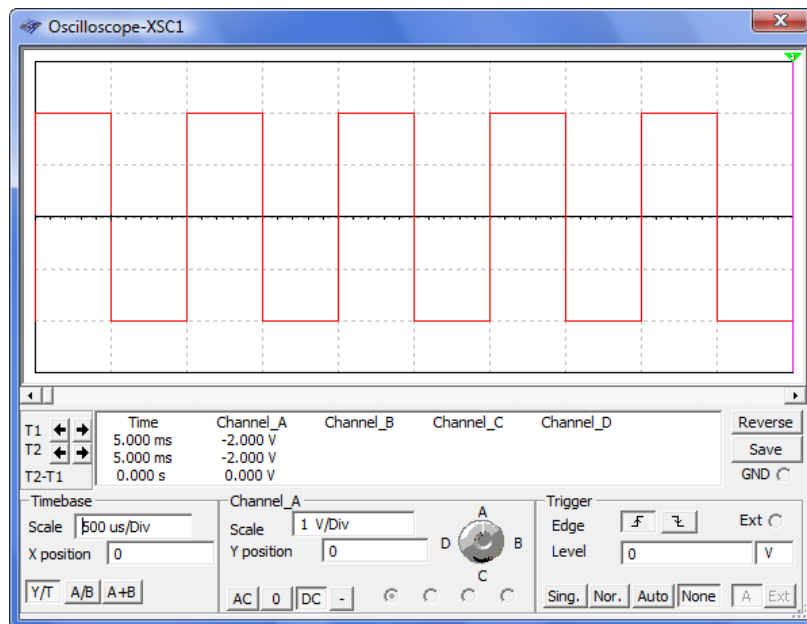

13. For each of the two digital signals shown below, determine the amplitude, period (T), frequency (F), time high ( $t_H$ ), time low ( $t_L$ ), and duty cycle (DC). Be sure to put your answer in proper engineering notation and use the correct units.

Amplitude:

Period:

Frequency:

Time High:

Time Low:

Duty Cycle:

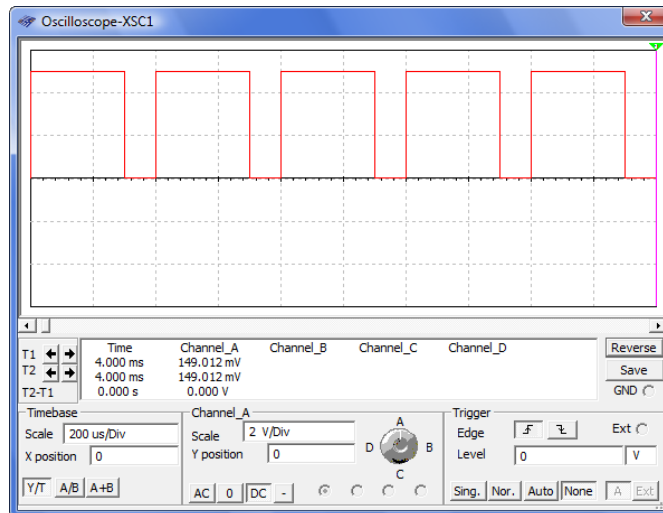

Amplitude:

Period:

Frequency:

Time High:

Time Low:

Duty Cycle:

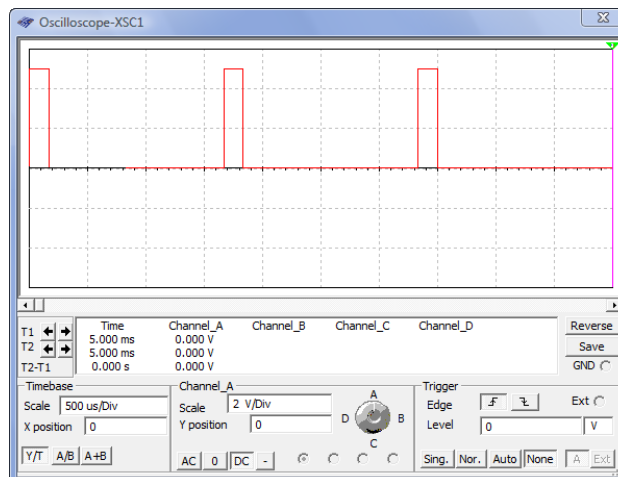



## Number Systems

14. Convert the following numbers.

- a.  $41_{(10)}$  \_\_\_\_\_ (2)
- b.  $96_{(10)}$  \_\_\_\_\_ (2)
- c.  $147_{(10)}$  \_\_\_\_\_ (2)
- d.  $864_{(10)}$  \_\_\_\_\_ (2)
- e.  $1056_{(10)}$  \_\_\_\_\_ (2)
- f.  $1000100010_{(2)}$  \_\_\_\_\_ (10)
- g.  $1111011_{(2)}$  \_\_\_\_\_ (10)
- h.  $1001110_{(2)}$  \_\_\_\_\_ (10)
- i.  $101011_{(2)}$  \_\_\_\_\_ (10)
- j.  $10010101_{(2)}$  \_\_\_\_\_ (10)

## Combinational Design Logic: AOI

15. Write the unsimplified SOP Equation for each Truth Table

$F_1 =$

X	Y	$F_1$
0	0	1
0	1	0
1	0	1
1	1	1

$F_2 =$

W	X	Y	$F_2$
0	0	0	1
0	0	1	0
0	1	0	1
0	1	1	0
1	0	0	0
1	0	1	1
1	1	0	1
1	1	1	0

$F_3 =$

W	X	Y	Z	$F_3$
0	0	0	0	1
0	0	0	1	0
0	0	1	0	0
0	0	1	1	0
0	1	0	0	0
0	1	0	1	0
0	1	1	0	1
0	1	1	1	0
1	0	0	0	0
1	0	0	1	0
1	0	1	0	0
1	0	1	1	1
1	1	0	0	1
1	1	0	1	0
1	1	1	0	0
1	1	1	1	0

16. Write the simplified SOP Equation for each of the above truth tables using BOOLEAN Logic.

17. Write the un-simplified Boolean expression that represents the logic circuit shown below.

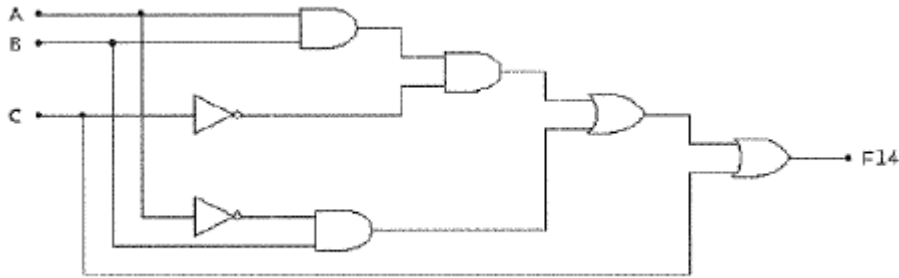

### Alternative Combinational Design Logic:

18. Draw the following SOP Equations using NAND Only Logic.

a.  $AB + CD + C$

b.  $A\bar{B} + \bar{B}C + C\bar{D}$

19. The Truth table shown at the right represents which gate? Draw the symbol that represents the gate and list the name and the equation.

X	Y	Z
0	0	1
0	1	1
1	0	1
1	1	0

20. Draw the truth table for the gate shown below.



21. Convert the following circuit to NOR only.

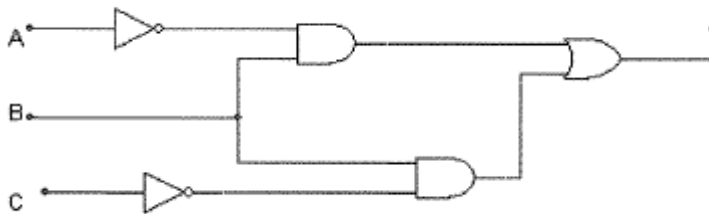

22. Using DeMorgan's Theorems, simplify each of the equations.

a.  $(\overline{W}X+WZ) + (\overline{W}Z + XZ)$

b.  $\overline{\overline{X}YZ} + \overline{\overline{X}YZ}$

23. Simplify using DeMorgan's Techniques

$$F_5 = \overline{\overline{A}B + C} + ABC + \overline{\overline{A} + B + C}$$

24. Create a K-map that represents the truth table show at the right and write down the simplified expression.

W	X	Y	Z	F
0	0	0	0	0
0	0	0	1	0
0	0	1	0	1
0	0	1	1	1
0	1	0	0	0
0	1	0	1	1
0	1	1	0	1
0	1	1	1	0
1	0	0	0	1
1	0	0	1	1
1	0	1	0	0
1	0	1	1	0
1	1	0	0	0
1	1	0	1	0
1	1	1	0	0
1	1	1	1	1

## Seven Segment Displays

25.

What logic values need to be placed on the inputs (a) through (g) of the common-cathode seven segment display in order to display the number 2?

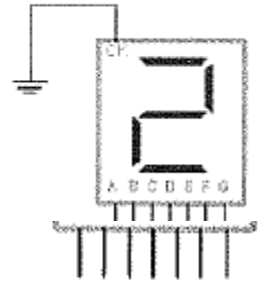

A	B	C	D	E	F	G

## Multiplexers and DeMultiplexers

26. Which of the following circuits is a half adder?

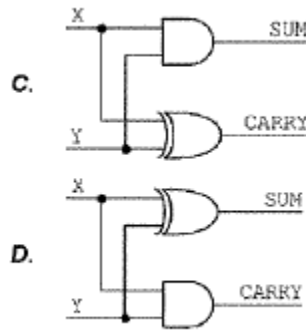
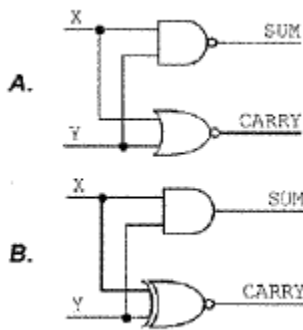

## Binary Addition

27. Perform the following binary addition problems

$$\begin{array}{r} 010011 \\ +100101 \\ \hline \end{array}$$

$$\begin{array}{r} 111011 \\ +011010 \\ \hline \end{array}$$

## Flip-Flops

28. What is the basic function of a flip-flop and transparent latch?
29. What functions do the synchronous and asynchronous inputs serve on flip-flops and transparent latches? Provide an example of each.
30. What are some of the typical applications of flip-flops? Describe how each of these applications work.
31. How are Q and Q' outputs of a flip flop affected by setting the active high asynchronous PRESET input to a logic one?
32. Draw the negative edge triggered flip flop with active high preset and clear in the space below.
33. What is the minimum number of flip flops needed to create a Mod-18 counter?
34. Look at the following counter. What is the count direction and range?

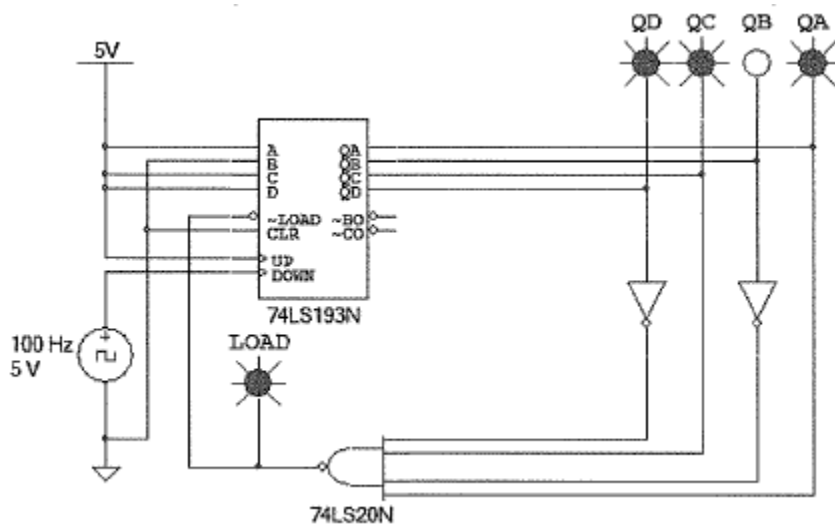



Using the incomplete, three-bit, asynchronous counter shown below as a starting point, design a counter that will display the binary numbers 5 down to 3 on the logic displays. You may add any additional logic as needed.

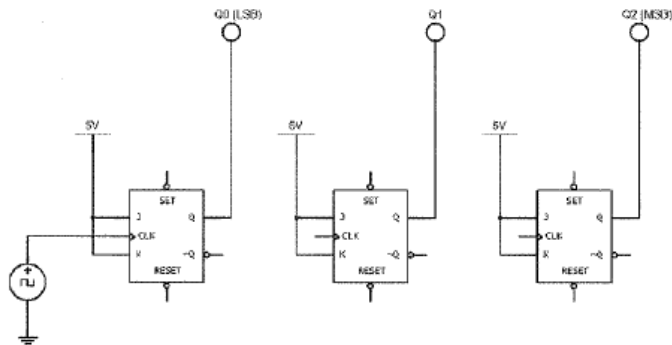

39.

40. What is the count range of the 3-bit asynchronous counter shown below.

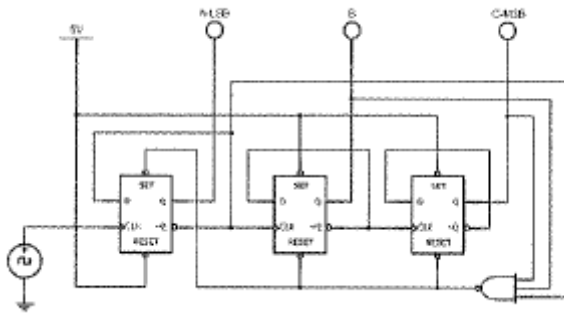

## State Machines

41. What is the basic function of a state machine?